

APG077N01G

N-Channel Enhancement Mosfet

Feature

- 100V,90A
 $R_{DS(ON)} < 7.7m\Omega @ V_{GS}=10V$ TYP: 6.2m Ω
 $R_{DS(ON)} < 10.0m\Omega @ V_{GS}=4.5V$ TYP: 8.5m Ω
- Split Gate Trench Technology
- Lead free product is acquired
- Excellent $R_{DS(ON)}$ and Low Gate Charge

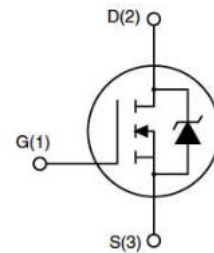

Schematic Diagram

Application

- PWM applications
- Load Switch
- Power management

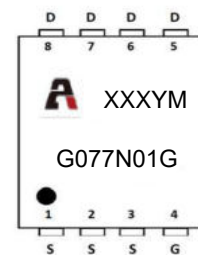

Marking and pin Assignment

Package Marking and Ordering Information

Device Marking	Device	Device Package	Reel Size	Tape width	Quantity (PCS)
G077N01G	APG077N01G	PDFN5X6	-	-	5000

ABSOLUTE MAXIMUM RATINGS ($T_J=25^\circ\text{C}$ unless otherwise noted)

Parameter	Symbol	Value	Unit
Drain-Source Voltage	V_{DS}	100	V
Gate-Source Voltage	V_{GS}	± 20	V
Continuous Drain Current ($T_C = 25^\circ\text{C}$) ⁽¹⁾	I_D	90	A
Continuous Drain Current ($T_C = 100^\circ\text{C}$) ⁽¹⁾	I_D	56	A
Pulsed Drain Current ⁽¹⁾	I_{DM}	360	A
Single Pulsed Avalanche Energy ($V_{DD} = 50V, L = 0.5mH$) ⁽²⁾	E_{AS}	225	mJ
Drain Power Dissipation	P_D	83	W
Thermal Resistance from Junction to Case	$R_{\theta JC}$	1.5	$^\circ\text{C/W}$
Thermal Resistance- Junction to Ambient	$R_{\theta JA}$	48	$^\circ\text{C/W}$
Junction Temperature	T_J	150	$^\circ\text{C}$
Storage Temperature	T_{STG}	-55~ +150	$^\circ\text{C}$

MOSFET ELECTRICAL CHARACTERISTICS(T_J=25°C unless otherwise noted)

Parameter	Symbol	Test Condition	Min	Type	Max	Unit
Static Characteristics						
Drain-source breakdown voltage	V _{(BR)DSS}	V _{GS} = 0V, I _D =250μA	100	-	-	V
Zero gate voltage drain current	I _{DSS}	V _{DS} =100V, V _{GS} = 0V	-	-	1	μA
Gate-body leakage current	I _{GSS}	V _{GS} = ±20V, V _{DS} = 0V	-	-	±100	nA
Gate threshold voltage ⁽³⁾	V _{GS(th)}	V _{DS} =V _{GS} , I _D =250μA	1.5	2.0	3.0	V
Drain-source on-resistance ⁽³⁾	R _{DS(on)}	V _{GS} =10V, I _D =40A	-	6.2	7.7	mΩ
		V _{GS} =4.5V, I _D =40A	-	8.5	10	mΩ
Forward Threshold Voltage	g _{fs}	V _{DS} =10V, I _D =40A	-	65	-	S
Gate Resistance	R _g	V _{DS} =V _{GS} =0V, f =1MHz	-	1.3	-	Ω
Dynamic characteristics						
Input Capacitance	C _{iss}	V _{DS} =50V, V _{GS} =0V, f =1.0MHz	-	3000	-	pF
Output Capacitance	C _{oss}		-	362	-	
Reverse Transfer Capacitance	C _{rss}		-	11	-	
Switching characteristics						
Turn-on delay time	t _{d(on)}	V _{DD} =50V, I _D =40A, R _G =3Ω, R _L =1.5Ω, V _G =10V	-	13	-	ns
Turn-on rise time	t _r		-	35	-	
Turn-off delay time	t _{d(off)}		-	20	-	
Turn-off fall time	t _f		-	15	-	
Total Gate Charge	Q _g	V _{DS} =50V, I _D =40A, V _{GS} =10V	-	30	-	nC
Gate-Source Charge	Q _{gs}		-	10	-	
Gate-Drain Charge	Q _{gd}		-	8	-	
Source-Drain Diode characteristics						
Diode Forward voltage ⁽³⁾	V _{SD}	T _J =25°C, V _{GS} =0V, I _S =20A	-	-	1.3	V
Diode Forward current	I _S	T _C =25°C	-	-	90	A
Body Diode Reverse Recovery Time	t _{rr}	T _J =25°C, I _F =20A, di/dt=100A/us		60		ns
Body Diode Reverse Recovery Charge	Q _{rr}	T _J =25°C, I _F =20A, di/dt=100A/us		90		uc

Notes:

1. Repetitive Rating: Pulse width limited by maximum junction temperature
2. L = 0.5 mH, V_{DD} = 50 V, I_{AS} = 30 A, R_G = 25 Ω, Starting T_J = 25 °C

Test Circuit

Gate Charge Test Circuit & Waveform

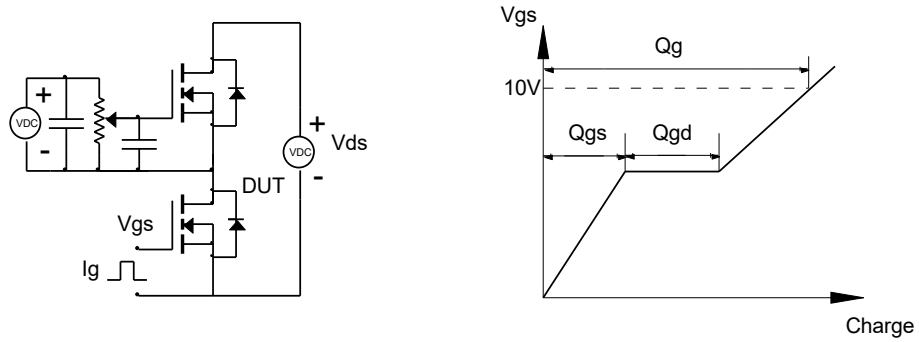

Resistive Switching Test Circuit & Waveforms

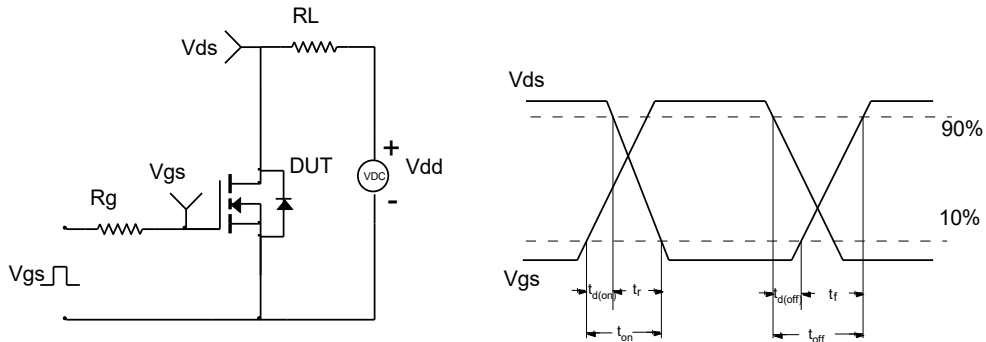

Unclamped Inductive Switching (UIS) Test Circuit & Waveforms

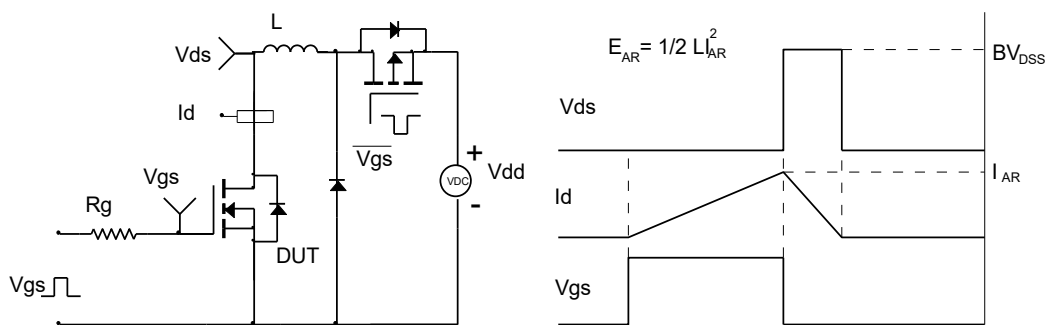

Diode Recovery Test Circuit & Waveforms

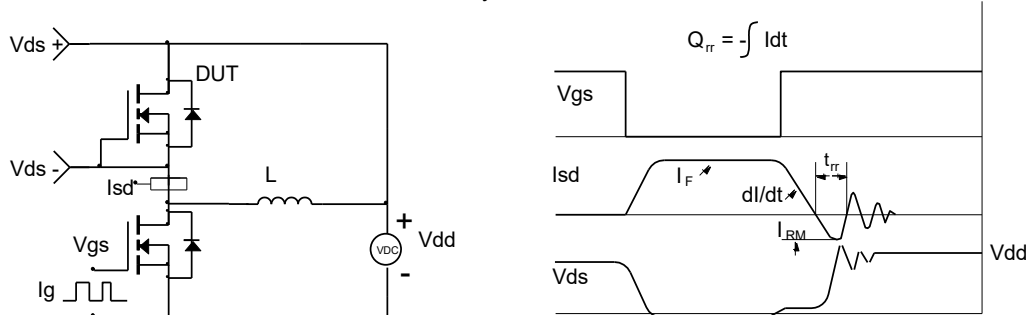

Typical Characteristics

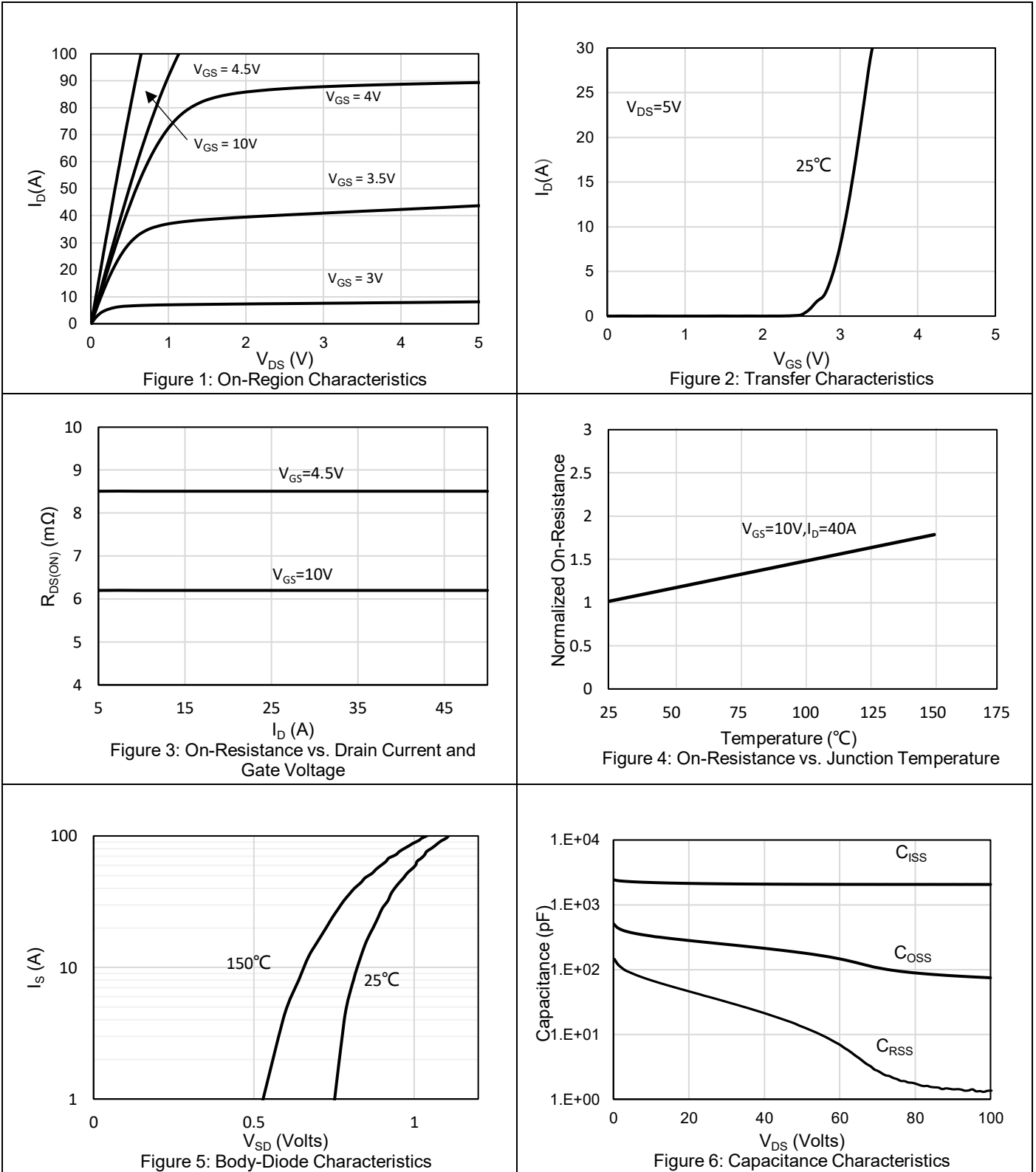

Typical Characteristics

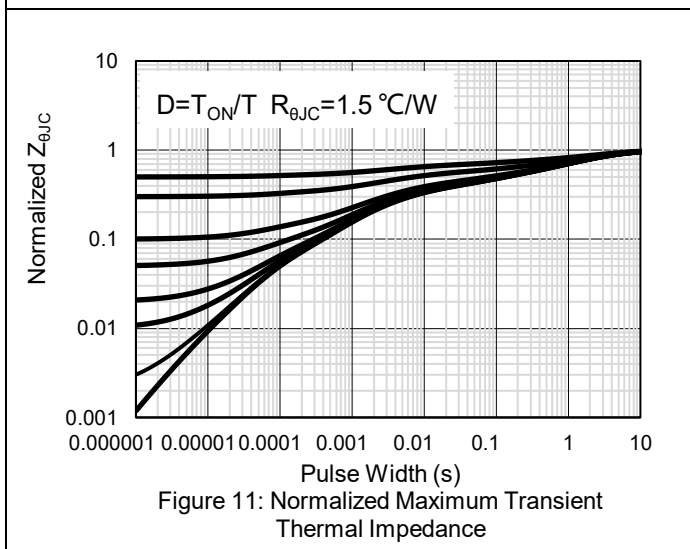
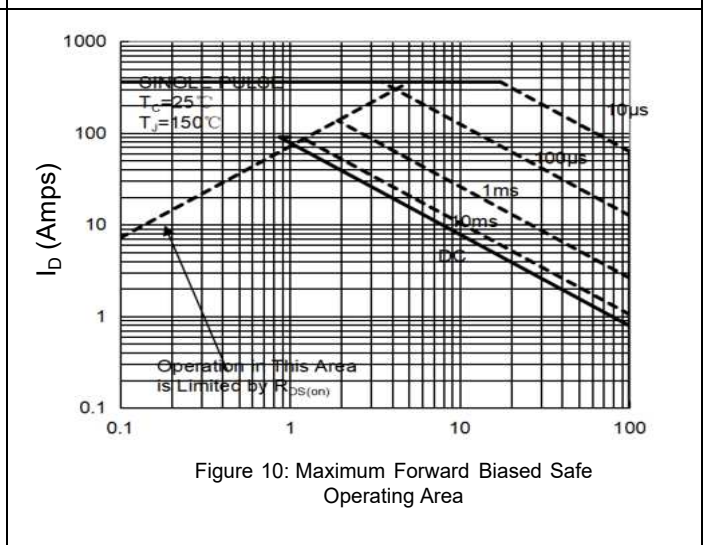
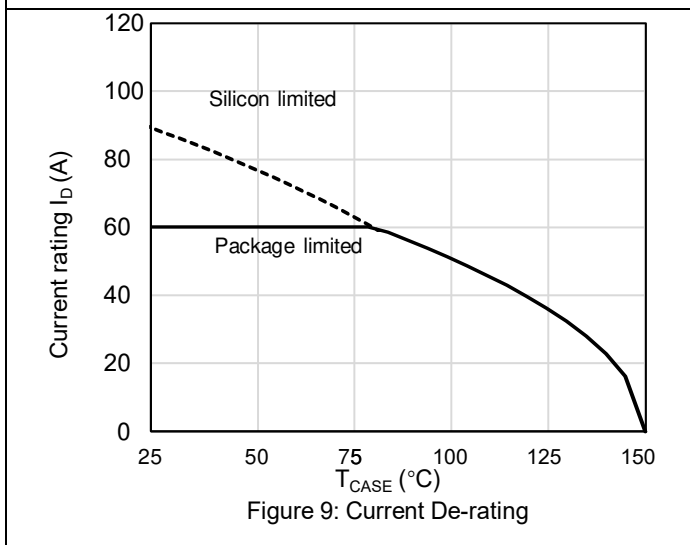
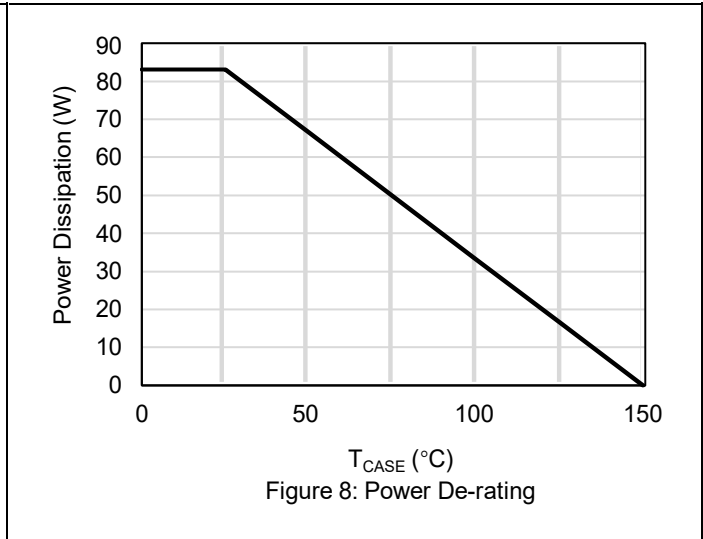
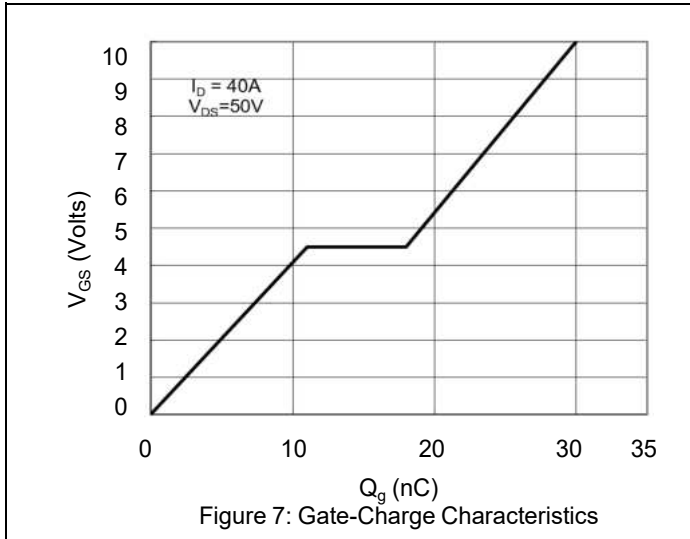

PDFN5X6 Package Information

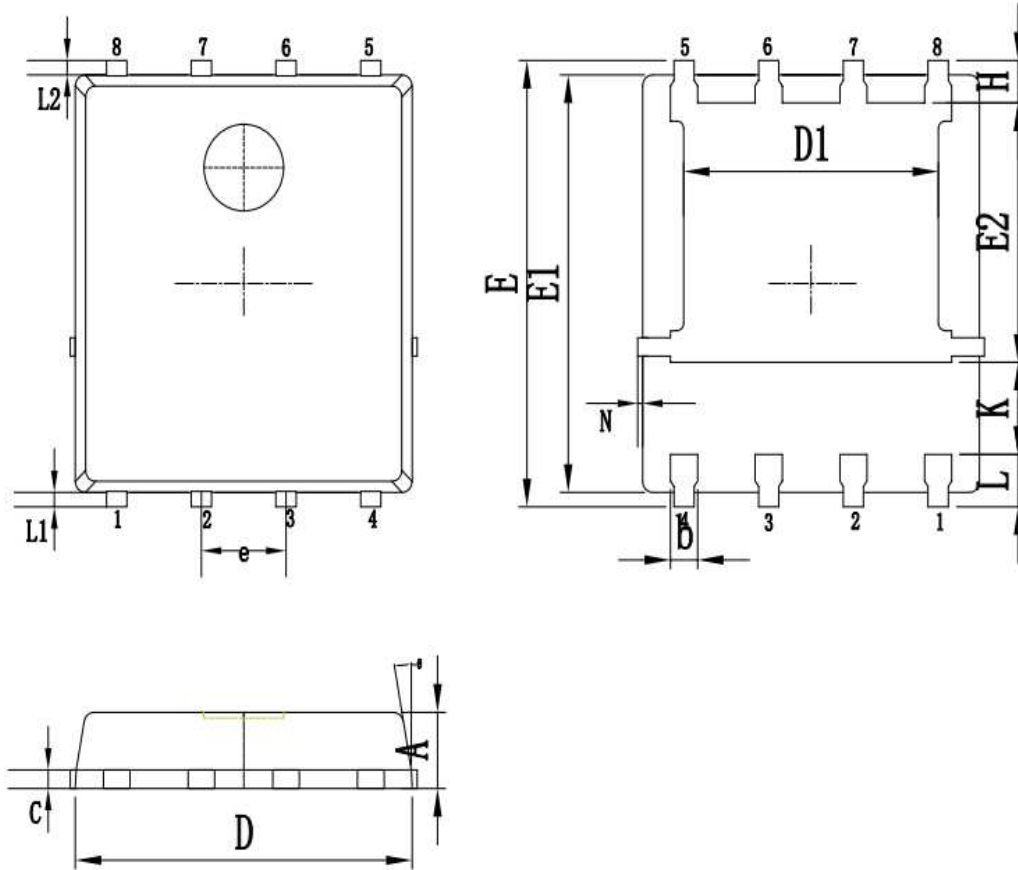

Symbols	Millimeters		
	MIN.	NOM.	MAX.
A	0.90	1.05	1.20
b	0.20	0.40	0.50
C	0.20	0.25	0.35
D	4.80	5.05	5.20
D1	3.80	3.90	4.10
E	5.90	6.00	6.20
E1	5.60	5.75	5.90
E2	3.40	3.50	3.60
e	1.27 BSC.		
H	0.40	0.60	0.70
K	1.17	1.27	1.37
L	0.50	0.74	0.84
L1/L2	0.10	0.16	0.20
θ	8°	10°	12°
N	0	-	0.15

Revision History

Revision	Release	Remark
V1.0	2024/05/14	Initial Release
V1.1	2024/08/10	Update POD

Disclaimer

The information given in this document describes the independent performance of the product, but similar performance is not guaranteed under other working conditions, and cannot be guaranteed when installed with other products or equipment. To achieve the required performance of the product in actual scenarios, the customer should conduct a complete application test to assess the functionality of the product.

Allpower assumes no responsibility for equipment failures result from using products at values that exceed the ratings, operating conditions, or other parameters listed in the product specifications.

The product described in this specification is not applicable for aerospace or other applications which requires high reliability. Customers using or selling these products for use in medical, life-saving, or life-sustaining applications do so at their own risk and agree to fully indemnify.

Due to product or technical improvements, the information described or contained herein may be changed without prior notice.